

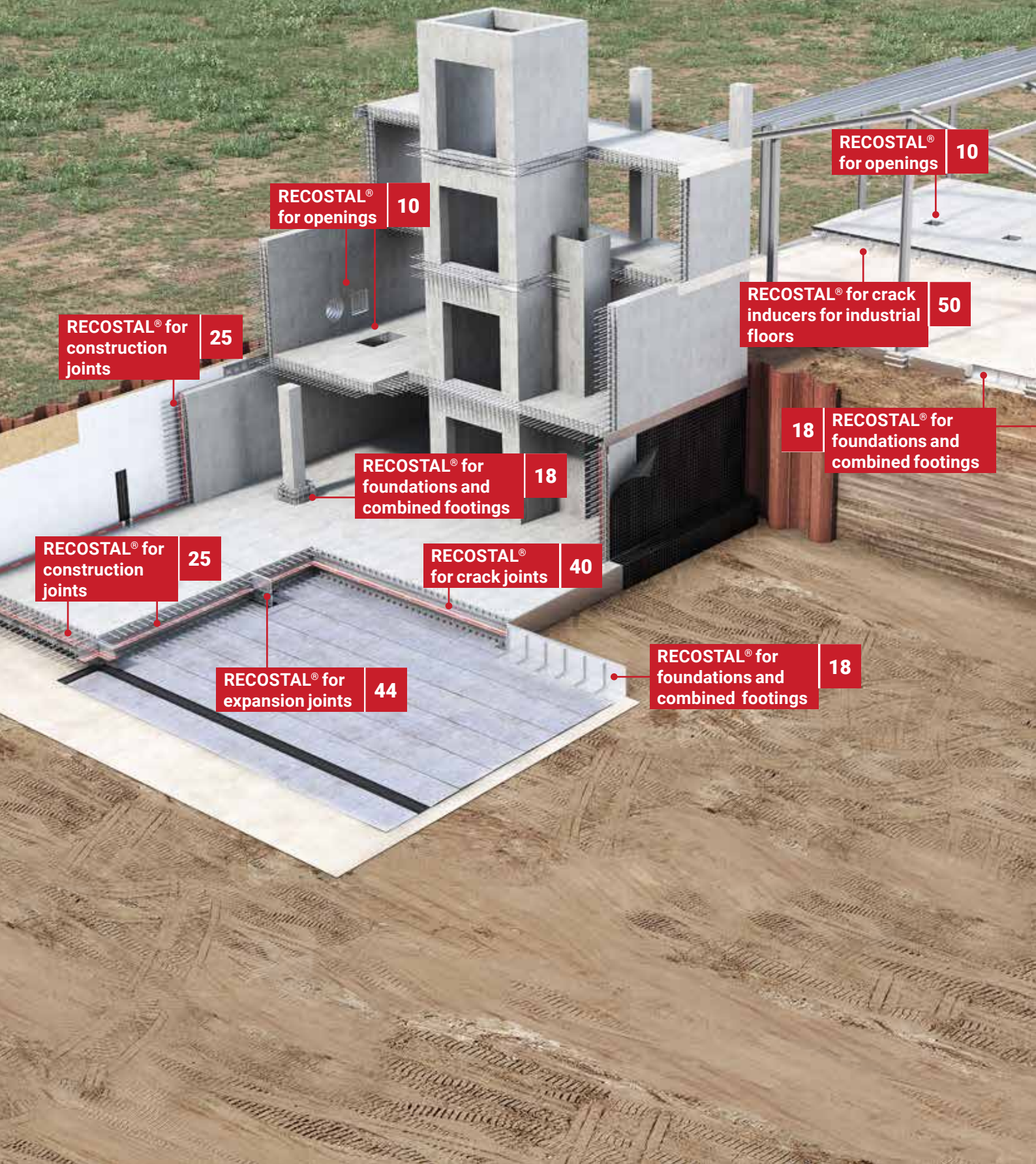

RECOSTAL[®]
Lost Formwork Technologies

RECOSTAL

BY DYWIDAG



RECOSTAL® for openings 10

RECOSTAL® for openings 10

RECOSTAL® for construction joints 25

RECOSTAL® for crack inducers for industrial floors 50

RECOSTAL® for foundations and combined footings 18

18 RECOSTAL® for foundations and combined footings

RECOSTAL® for construction joints 25

RECOSTAL® for crack joints 40

RECOSTAL® for expansion joints 44

RECOSTAL® for foundations and combined footings 18

Table of contents

• About us	4
• Application areas for RECOSTAL® technology	6
• Selected projects with RECOSTAL® solutions	8
• Shuttering units RECOSTAL® for making openings	
RECOSTAL® SBOX	10
RECOSTAL® SF	12
Tulo pipes	14
• Shuttering units RECOSTAL® for foundations and combined footings	
RECOSTAL® Speed Edge	18
RECOSTAL® FS/ES/ET	20
RECOSTAL® BOX	23
• Shuttering units RECOSTAL® for making construction joints	
RECOSTAL® Expanded metal	25
RECOSTAL® 1000	27
RECOSTAL® 2000	29
RECOSTAL® 2000 GT/ GT-Z	31
• Shuttering units RECOSTAL® for making construction joints with pvc tape or metal waterstops	
RECOSTAL® Edge Forms	33
• Shuttering units RECOSTAL® for making construction joints with bentonite or bitum sealing	
RECOSTAL® 1000 F	34
RECOSTAL® 2000 F	36
RECOSTAL® 2000 GTF/ GTF-Z	38
• Shuttering units RECOSTAL® for making crack joints	
RECOSTAL® 3000	40
RECOSTAL® 3000 F	42
• Shuttering units RECOSTAL® for making expansion joints	
RECOSTAL® DFI	44
RECOSTAL® DFA	46
RECOSTAL® DFI-DFA	48
• Shuttering units RECOSTAL® for making crack inducers for industrial floors	
RECOSTAL® Keyboard XL-D	50
RECOSTAL® Keyboard XLV/XLW-D	52
RECOSTAL® Keyboard XLS	54



Supporting infrastructure by making it safe and strong has been our story since 1865.

We've grown to 1,500+ employees and 25 licensees in 50+ countries.

From the steel in our first reinforced bridge in 1903, to remote robots scanning stay cable health - we help extend the lifespan of the world's new and aging infrastructure.

Private and public asset owners, engineers, and construction companies use our technology for projects across sectors like bridges, buildings, ground stabilization, wind towers, and tunnels. Projects include The Golden Gate Bridge, Panama Canal, Kap Shui Mun Bridge, and Freedom Tower.

The needs of infrastructure have changed - and so have we. Our roots? Bridges, one of the most complex civil structures, which require safety and strength in all kinds of demanding environments. Although we were founded as a concrete company, that changed in the early 20th century when we found our focus as a multi-sector civil construction project (and maintenance) sub-contractor.

For over 100 years, the main product the construction industry thinks of after hearing DYWIDAG, is our threadbar - likely found in a significant amount of the infrastructure in your city.

DYWIDAG is a well-known company for geotechnics and post tensioning. But there's more: DYWIDAG Form tie systems, sealing technologies CONTEC®, lost formwork and reinforcement technologies RECOSTAL® which are one business unit called DYWIDAG Concrete Technologies.

Our technologies are widely recognized for highly secure systems. Our main production is in Poland and Germany. Products carry approvals to international quality standards. The coating of the metal waterstops consists of highly swelling bentonite.

Our timeline:

- 1865** Dyckerhoff & Widmann AG (DYWIDAG) founded a small concrete construction company.
- 1950** DYWIDAG starts license business for construction systems with bridge post-tensioning at its core.
- 1979** DYWIDAG SYSTEMS INTERNATIONAL (DSI) founded to expand international business. Invests in R&D and a second global segment: geotechnics.
- 2006** DSI enters the European concrete accessories market by making acquisitions in France and Germany: Arteon, Technique Beton, Mandelli-Setra, CONTEC®.
- 2011** Private equity investor Triton becomes the new shareholder of DSI.
- 2016** Development of construction activities in Middle East & Asia, including new joint ventures in Qatar and India.
- 2018** Alpin Technik and Datum Group acquired to empower DSI's robotics and monitoring.
- 2018** Concrete accessories created as a Business Unit within DYWIDAG.
- 2019** DSI acquires PARTEC.
- 2020** DSI rebrands as DYWIDAG.
- 2021** DY.CO launched as a new Pan-European Business Unit of DYWIDAG.
- 2023** DY.CO rebrands as DYWIDAG Concrete Technologies.

DYWIDAG CONCRETE TECHNOLOGIES

- 40+ years of experience
- Resellers in 40+ countries
- Tailor-made products
- Quality and safety orientation
- Made in Europe

Applications

- Commercial Buildings
- Residential Construction
- Civil Engineering
- Precast Concrete Elements
- Structural Repair

Customers

- General Contractors
- Distributors
- Applicators

Our product brands

RECOSTAL® Reinforcement Technologies

RECOSTAL® Lost Formwork Technologies

CONTEC® Sealing Technologies

DYWIDAG® Surface Sealing Technologies

DYWIDAG Form Ties Systems

End markets



Construction

Commercial buildings/ Residential/
Non-residential/ Hospital/ Datacenter



Agriculture

Biogas plants/ Silage storage



Industrial

Production/ Warehouse



Power

Nuclear power plant/ Hydroelectric power plant



Infrastructure

Tunnels/ Bridges

Applications of RECOSTAL[®]

Lost Formwork

Lost formwork is a highly precise and versatile solution that accelerates the construction process, reduces labor and costs, and ensures greater accuracy in forming complex shapes while achieving ideal concrete surfaces. It provides uniform and stable support for concrete during curing, resulting in stronger and more durable structural elements. Lost formwork enables the creation of thinner walls or slabs without compromising strength, optimizing interior space utilization in buildings. Additionally, it remains in the structure, avoiding the need for labor-intensive dismantling, inventory management, storage, or returning to rental services, which often generates additional costs.

The primary benefits of lost formwork are significant labor cost savings and a shorter construction process. Its lightweight design and ease of installation allow most operations to be performed by a single person, without a crane, and much faster than traditional methods, even with less-skilled workers.

Lost formwork has broad applications in various construction fields, primarily in reinforced concrete structures.

Key application areas of Lost Formwork

Foundations and footings



Lost formwork is frequently used for shaping foundation footings and foundations of any shape, including complex geometries. Pre-fabricated lost formwork elements are produced with high precision, ensuring better control over dimensions and foundation quality. This helps avoid irregularities that are critical to the stability of the entire structure.

Openings in slabs



Lost formwork is used to create openings in slabs for installations or vertical shafts. It ensures accurate replication of planned slab openings, avoiding issues with later cutting or corrections, which can be time-consuming and costly with traditional methods. Conventional techniques can introduce unwanted stresses into the structure, weakening it or causing cracks. Lost formwork allows for even load distribution.

Expansion joints



Expansion joints separate different parts of a concrete structure that may experience different loads or movements, such as building wings or bridge segments. They allow for independent movement of one part relative to another. Lost formwork ensures controlled load transfer between structural elements, compensates for stresses, and allows free movement due to temperature changes, concrete shrinkage, or building settlement. This minimizes the risk of cracks and structural damage, increasing the lifespan of the structure.

Construction joints

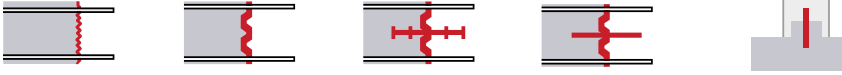

Lost formwork used in construction joints is widely adopted in reinforced concrete construction. These joints are created when concreting work is divided into stages, often due to technological breaks. Lost formwork left within the structure ensures durable and secure connections between individual concrete sections. Construction joints can include sealing sheets to prevent water and moisture penetration, which is especially important in foundations, retaining walls, and other water-exposed structures.

Industrial floors and slabs



Lost formwork facilitates the creation of expansion joints and divisions between different sections of flooring, crucial for large surfaces such as warehouses, factories, or logistics centers. This enables the flooring to work; under temperature changes and loads, minimizing the risk of cracks. Using lost formwork allows precise planning of floor reinforcements at critical points. It also acts as an additional layer of reinforcement, enhancing resistance to compression and dynamic loads. Lost formwork ensures perfectly straight edges and divisions.

Reinforced concrete walls



Lost formwork speeds up the construction of monolithic reinforced concrete walls by eliminating the need for dismantling, which is especially useful in multi-story construction.

Tunnels and culverts



Lost formwork performs exceptionally well in challenging geological conditions due to its design flexibility and adaptability to specific geometric requirements. Made from high-strength materials, it provides additional support for tunnel walls and ceilings, reducing the risk of structural damage. Groundwater penetration is a common issue in tunnels; lost formwork integrated with sealing systems effectively prevents leaks, ensuring long-term waterproofing.

Selected projects using RECASTAL® products



**Hinkley Point C Nuclear Power Station,
United Kingdom**

YEAR OF EXECUTION: from 2012
CLIENT/OWNER: EDF Energy, China General Nuclear Power Group
GENERAL CONTRACTOR: Laing O'Rourke in cooperation with Bouygues TP (Bylor)
SCOPE: Supply, technical support
RECASTAL® FORMWORK USED:
 RECASTAL® 2000 GT, RECASTAL® Sbox



**Töging-Jettenbach Power Station,
Germany**

YEAR OF EXECUTION: 2018 - 2022
CLIENT/OWNER: Verbund Innkraftwerke GmbH
GENERAL CONTRACTOR: PORR GmbH & Co. KGaA
SCOPE: Supply, technical support
RECASTAL® FORMWORK USED:
 RECASTAL® 2000 GT



**Power plant in Jaworzno,
Poland**

YEAR OF EXECUTION: 2015 - 2019
CLIENT/OWNER: TAURON
GENERAL CONTRACTOR: Rafako, Mostostal
SCOPE: Supply, technical support
RECASTAL® FORMWORK USED:
 RECASTAL® 1000 F



**Track from Drammen to Kobbervikdalen,
Norway**

YEAR OF EXECUTION: from 2019
CLIENT/OWNER: BANE NOR
GENERAL CONTRACTOR: Veidekke
SCOPE: Supply, technical support
RECASTAL® FORMWORK USED:
 RECASTAL® DFI-DFA



**Onshore LNG Terminal in Stade,
Germany**

YEAR OF EXECUTION: 2024 - present
CLIENT/OWNER: Hanseatic Energy Hub company, involving several partners: Partners Group, Enagás, Dow and Buss Group
GENERAL CONTRACTOR: Consortium of Tecnicas Reunidas (leader) and FCC and Enka (partners)
SCOPE: Supply, technical support
RECASTAL® FORMWORK USED:
 RECASTAL® 1000, RECASTAL® 2000 GT



**MOSE project protecting Venice,
Italy**

CLIENT/OWNER: Venice Water Authority
GENERAL CONTRACTOR: Consorzio Venezia Nuova
SCOPE: Supply, technical support
RECASTAL® FORMWORK USED:
 RECASTAL® 2000 GTF-Z



**WESTGATE shopping centre in Oxford,
United Kingdom**

YEAR OF EXECUTION: 2016 - 2017
CLIENT/OWNER: Land Securities & The Crown Estate
GENERAL CONTRACTOR: Laing O'Rourke
SCOPE: Supply, technical support
RECASTAL® FORMWORK USED:
 RECASTAL® 2000 GT



**Residential & Office Building Pontkade,
Netherlands**

YEAR OF EXECUTION: from 2022
SCOPE: Supply, technical support
RECASTAL® FORMWORK USED:
 RECASTAL® Foundation Formwork



**Municipal stadium in Wrocław,
Poland**

YEAR OF EXECUTION: 2009 - 2011
CLIENT/OWNER: Stadion Wrocław, Wrocław
GENERAL CONTRACTOR: Mostostal Warszawa, Max Boegl
SCOPE: Supply, technical support
RECASTAL® FORMWORK USED:
 RECASTAL® Box, RECASTAL® 2000 GT



**Golden Taraces shopping centre,
Poland**

YEAR OF EXECUTION: 2002 - 2007
CLIENT/OWNER: Złote Tarasy Sp. z o.o.
GENERAL CONTRACTOR: Skanska
SCOPE: Supply, technical support
RECOSTAL® FORMWORK USED:
 RECOSTAL® 2000



**Residential building in Warsaw,
Poland**

YEAR OF EXECUTION: from 2022
CLIENT/OWNER: Marvipol Development SA
GENERAL CONTRACTOR: Karmar SA
SCOPE: Supply, technical support
RECOSTAL® FORMWORK USED:
 RECOSTAL® 1000 F



**Sea Towers in Gdańsk,
Poland**

YEAR OF EXECUTION: 2006 - 2009
CLIENT/OWNER: Invest Komfort SA
GENERAL CONTRACTOR: Invest Komfort SA
SCOPE: Supply, technical support
RECOSTAL® FORMWORK USED:
 RECOSTAL® 1000



**Pasaż Grunwaldzki shopping centre in
Wrocław, Poland**

YEAR OF EXECUTION: 2005 - 2007
CLIENT/OWNER: Echo Investment S.A.
GENERAL CONTRACTOR: Strabag Sp. z o.o.
SCOPE: Supply, technical support
RECOSTAL® FORMWORK USED:
 RECOSTAL® 1000



**Dominikańska gallery in Wrocław,
Poland**

YEAR OF EXECUTION: 1999 - 2001
CLIENT/OWNER: ECE Projektmanagement Polska
GENERAL CONTRACTOR: Hochtief Polska
SCOPE: Supply, technical support
RECOSTAL® FORMWORK USED:
 RECOSTAL® 1000, RECOSTAL® Sbox



**Shopping mall Galeria Piastow,
Poland**

YEAR OF EXECUTION: 2006 – 2009
CLIENT/OWNER: Rank Progress S.A.
GENERAL CONTRACTOR: ERBUD SA, Technobud
 Nowy Sącz
SCOPE: Supply, technical support
RECOSTAL® FORMWORK USED:
 RECOSTAL® 1000



**VELA Hotels,
Germany**

YEAR OF EXECUTION: 2019 - 2021
CLIENT/OWNER: Vela Hotels AG
GENERAL CONTRACTOR: VENTIS Holding AG
SCOPE: Supply, technical support
RECOSTAL® FORMWORK USED:
 RECOSTAL® 2000 GTF



**Gramercy Tower in Cardiff,
United Kingdom**

YEAR OF EXECUTION: from 2023
CLIENT/OWNER: Urban Centric (Cardiff) Limited
GENERAL CONTRACTOR: Intelle Construction
SCOPE: Supply, technical support
RECOSTAL® FORMWORK USED:
 RECOSTAL® Sbox



**Saatwinkler Damm in Berlin,
Germany**

YEAR OF EXECUTION: from 2021
CLIENT/OWNER: SEED 1 GmbH
GENERAL CONTRACTOR: Ten Brinke GmbH
SCOPE: Supply, technical support
RECOSTAL® FORMWORK USED:
 RECOSTAL® 2000 GTF, RECOSTAL® DFI

RECOSTAL® Sbox

RECOSTAL® Sbox are made for easily adding openings in buildings and structures. They form a strong bond with concrete and can come in different shapes and groups of openings. If needed, RECOSTAL® Sbox can be produced with fixing brackets for easier installation. There is no need for stripping, and they can also be made from expanded metal.

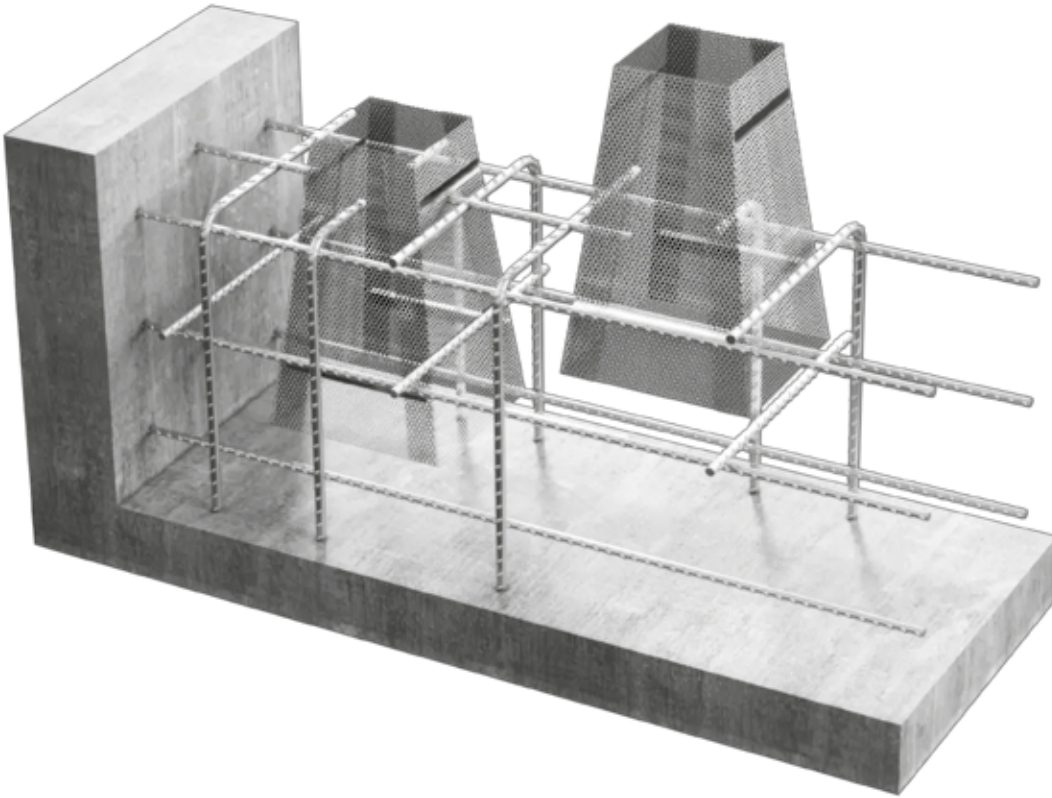

Benefits

- Strong bond with concrete
- Many shape variants possible
- With fixing brackets on request
- No stripping required

Product variants

- RECOSTAL® Sbox CM – corrugated metal sheet
- RECOSTAL® Sbox SM – smooth metal sheet
- RECOSTAL® Sbox TM – trapezoidal metal mesh

Examples of Sbox shapes

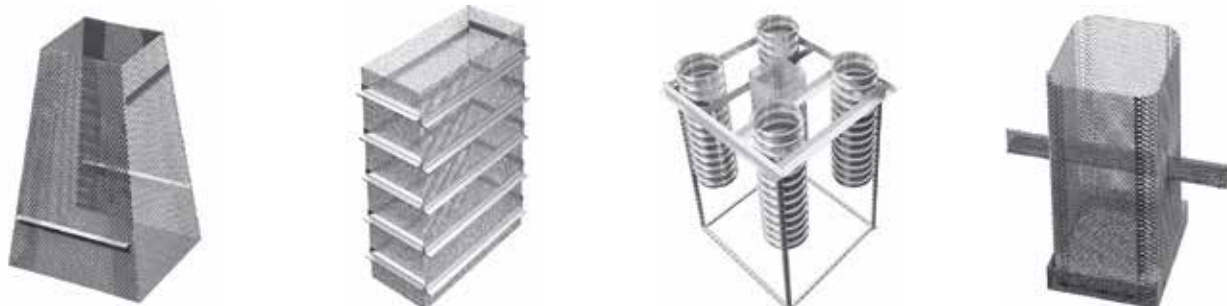

Installation

Secure the RECOSTAL® Sbox between the reinforcement or to the reinforcement layer. Fix with fixing brackets directly to the blinding layer or the formwork. RECOSTAL® Sboxes are self-supporting in most dimensions and installation situations. Depending on the concrete pressure, on-site support must be provided.

Required information to place an order

- 1: Dimensions: A x B / C x D / H
- 2: Thickness: 0.7/ 1.0/ 1.5 mm
- 3: Product's option: CM/SM/TM
- 4: Quantity



Technical data

- Material: Galvanized steel sheet, black steel mesh
- Sheet thickness: 0.7, 1.0, 1.5 mm
- Packaging: packed on pallets, shrink wrapped
- Box dimensions : Height, width/diameter and length by order
- Storage: no limitation

RECOSTAL® SF

RECOSTAL® SF are coiled formwork units designed to install openings in structural and civil engineering.

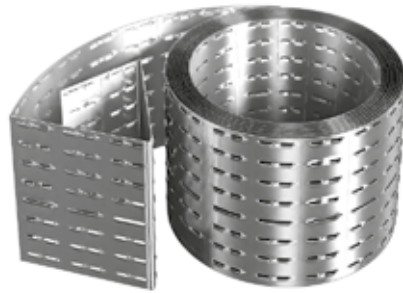

Benefits

- Strong bond to concrete
- Many sizes possible due to pre-punching profiling at distance of 5 cm
- Easy vertical bending
- Various shape possible

Selected shapes of RECOSTAL® SF

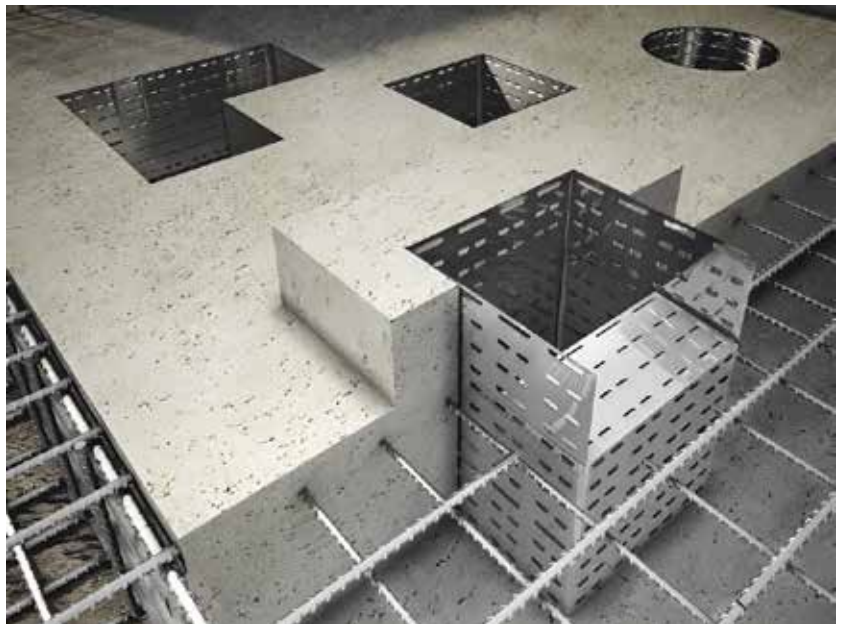
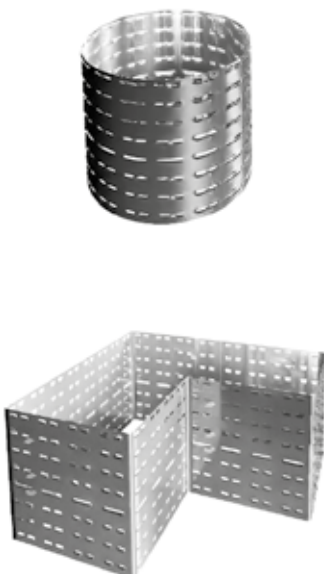

Technical data

- Material: profiled, pre-punching sheet steel
- Thickness mesh: 0.7 mm
- Packaging: packed on pallets, 10 m rolls
- Storage: in stock / by order

TYPE	HEIGHT H [m]	LENGTH L [m]	QUANTITY [m/pal.]
SF 14	14	10	480
SF 16	16	10	480
SF 18	18	10	420
SF 20	20	10	360
SF 22	22	10	360
SF 24	24	10	300
SF 26	26	10	300
SF 28	28	10	300
SF 30	30	10	300

Installation

Unroll the SF tape to the required length and cut to size with metal shears or timmer. Create needed shape and join the overlaps of SF tape using tie wire. Place the finished opening form in the planned structure and secure into position, as well as stiffening.

Step 1 Splitting the tape in such a way as to get the required shape.

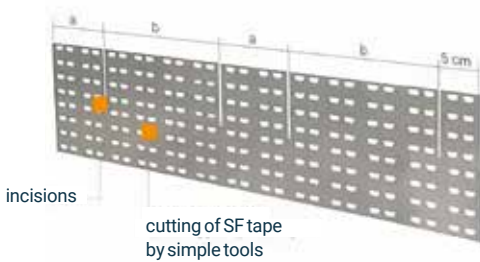

Step 2 Bending the tape.

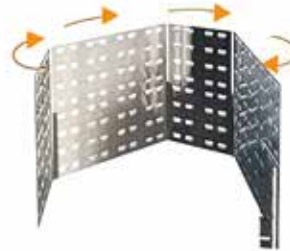

Step 3 Forming the required shape.

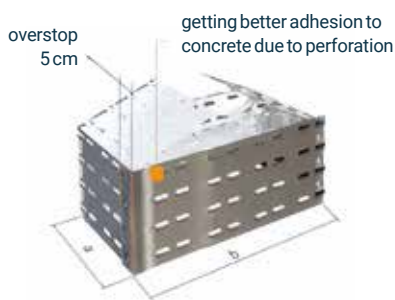

Step 4 Installation of RECOSTAL® S and SF tape elements on tables for production of prefabricated components.



Step 5 Pouring of concrete mix in the prefabrication plant.



Step 6 Bending of RECOSTAL® SF tape and pouring of concrete mix on finished ceiling panel.



If necessary, brace with scantlings/bars during concreting.

TULO Pipe

TULO pipes are a permanent formwork made from spiral sheet metal. They are available in both round and rectangular profiles. TULO pipes are primarily used as recess formers for ceilings and walls as well as foundations for machines, poles and masts.

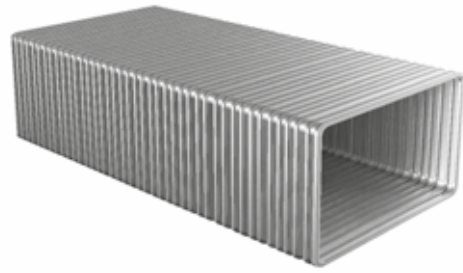

Benefits

- Spiral profile
- Round and rectangular profiles
- Fast Installation
- Special types and sizes on request

Product variants

- Round profile
- Rectangular profile

Round profile

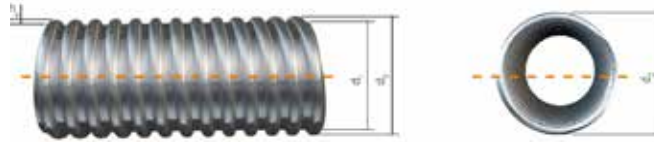

Type	Diameter d_1 [mm]	Diameter d_2 [mm]	Height h_p [mm]	Weight [kg/m]
30	30	35	2.5	0.20
40	40	46	3.0	0.20
50	50	56	3.0	0.34
60	60	67	3.5	0.46
65	65	72	3.5	0.56
70	70	77	3.5	0.57
80	80	87	3.5	0.77
90	90	97	3.5	0.80
100	100	108	3.8	0.85
125	125	133	3.8	1.11
150	150	158	3.8	1.28
180	180	188	3.8	1.55
200	200	208	3.8	1.70
250	250	260	4.8	2.24
290	290	300	4.8	2.50
300	300	310	4.8	2.68
310	310	320	4.8	2.80
350	350	360	4.8	3.11
400	410	410	4.8	3.55
450	434	450	8.0	5.59
500	484	500	8.0	6.22
550	534	550	8.0	6.96
600	584	600	8.0	7.49
650	634	650	8.0	8.12
700	685	700	8.0	10.99
750	735	756	8.0	11.78
800	785	800	8.0	12.58
850	835	850	8.0	13.37
900	885	900	8.0	14.17
950	935	950	8.0	14.96
1000	985	1000	8.0	20.10
1050	1035	1050	8.0	22.33
1100	1086	1108	8.0	24.36
1150	1130	1158	8.0	25.48
1250	1230	1250	8.0	27.70
1350	1330	1350	8.0	30.20
1500	1480	1500	8.0	33.28

Rectangular profile

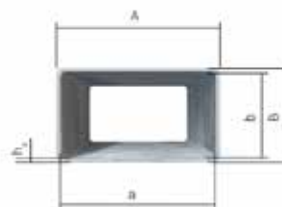

Type	Height/Width a x b [mm]	Height/Width A x B [mm]	Height h _p [mm]	Weight [kg/m]
30 x 30	28 x 28	35 x 35	3.5	0.26
40 x 40	41 x 41	49 x 49	3.5	0.50
50 x 50	49 x 49	59 x 59	3.5	0.55
60 x 60	62 x 62	70 x 70	3.5	0.76
60 x 30	57 x 28	67 x 36	3.5	0.54
70 x 70	72 x 72	82 x 82	3.5	0.88
70 x 35	69 x 35	77 x 45	3.5	0.66
80 x 80	82 x 82	90 x 90	3.5	1.01
80 x 40	77 x 42	85 x 50	3.5	0.86
90 x 60	90 x 60	98 x 68	3.5	1.02
100 x 50	102 x 52	110 x 60	3.5	0.97
100 x 100	100 x 100	108 x 108	3.5	1.15
130 x 60	130 x 60	138 x 68	3.5	1.38
130 x 130	130 x 130	138 x 138	3.5	1.65
140 x 80	140 x 80	149 x 88	3.5	1.38
140 x 140	138 x 138	149 x 149	3.5	1.70
160 x 100	160 x 100	168 x 168	3.5	1.65
200 x 200	186 x 186	197 x 197	3.5	2.35

Technical data

- Material: steel sheet metal
- Unit length: 500 cm
- Packaging: packed on pallets, shrink wrapped
- Unit diameter = 3 - 150 cm
- Unit widths/heights = 3 - 200 cm
- Storage: no limitation

Installation

The TULO pipes is fixed directly to the main reinforcement of the wall or slab.



After fixing formworking and concreting can start around the pipes.



When the concrete cures formwork can be stripped and the recesses are complete.



RECOSTAL® Speed Edge

RECOSTAL® Speed Edge is widely regarded as one of the most effective permanent formwork systems for reinforced concrete base and floor slabs in commercial and industrial construction. One of the standout features of the RECOSTAL® Speed Edge system is its rapid and easy installation process, which significantly reduces labor time on site. The formwork panels are lightweight and modular, allowing for quick positioning and alignment. RECOSTAL® Speed Edge, as a permanent formwork, reduces the need for additional labor and materials required for removal. The system becomes an integral part of the floor slab, providing lasting structural benefits without the hassle of temporary formwork removal, saving both time and costs.



Benefits

- Time Savings – Installation of 1 meter of RECOSTAL® Speed Edge is 6 times faster than the traditional method due to the simplicity of the solution, narrower foundation excavations (about 1 meter), and no need for dismantling
- Cost Reduction – Only 1 person is needed for installation, there is no need for a crane, and less backfilling is required
- Self-Supporting up to H=50 cm confirmed in appropriate concreting tests
- Low Transportation and Storage Costs
- Easy to Form Corners



Technical data

- Material: galvanized steel sheet metal
- Material thickness: 0.7 to 1.2 mm
- Unit length: 225 cm
- Installation heights: 14 to 50 cm (self-supporting)
50 to 100 cm (external support needed)
- Packaging: packed on pallets, shrink wrapped
- Storage: no limitations

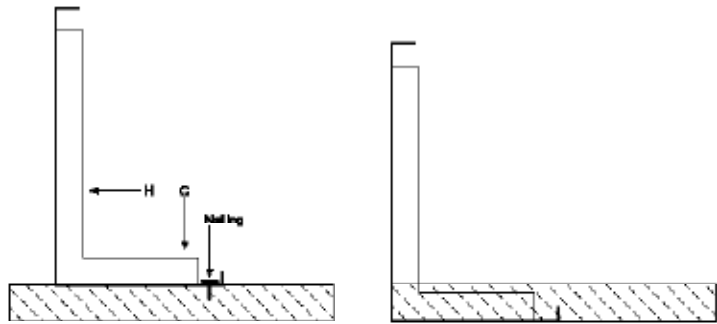

Type	Item No	Height H [cm]	Width B [cm]	Length L [m]	Units per pallet [No./m]
R14	14010014	14	12	2.25	204/459
R16	14010016	16	12	2.25	170/382.5
R18	14010018	18	12	2.25	170/382.5
R20	14010020	20	12	2.25	120/270
R22	14010022	22	13	2.25	120/270
R24	14010024	24	14	2.25	120/270
R25	14010025	25	15	2.25	90/202.5
R26	14010026	26	16	2.25	90/202.5
R28	14010028	28	17	2.25	90/202.5
R30	14010030	30	18	2.25	90/202.5
R35	14010035	35	21	2.25	60/135
R40	14010040	40	24	2.25	60/135
R45	14010045	45	27	2.25	60/135
R50	14010050	50	30	2.25	60/135

Installation



Position RECOSTAL® Speed Edge Formwork on the blinding level (important to prevent concrete leakage) and fix with nails driven through the nail holes provided along the base of the unit.



When setting up on a gravel support layer, use appropriate extra long nails.



Joints are installed by simply pushing together the units with 3-4 cm overlap.



Create corners by cutting the sheet metal base and bending the unit on site.



Concreting of foundation slab.

RECOSTAL® ES/ET/FS Foundation Formwork

RECOSTAL® Foundation Formwork is a complete assembly system with key profiled shuttering units. The accessories support the system and enable the unobstructed installation of the reinforcement. The formwork is self-supporting up to a height of $H = 1.0$ m. The distance of the accessories is always ≤ 1.0 m. The tube diameter varies depend on the height of foundations. There are three types of RECOSTAL® Foundation Formwork: ES, FS, ET.

Self-supporting foundation formwork type FS and ES as complete assembly system with trapezoidal profiled formwork units. All parts are precision-made and pre-fabricated according to the layout plan. Due to the form ties and formbraces (accessories) provided with the formwork units, the system is self-supporting up to a formwork height of $H = 1.0$ m. Foundation formwork type ET as an assembly system with trapezoidal profiled formwork units. All parts are precision-made and pre-fabricated according to the layout plan. Overlaps are fixed with hexagon head screws, which are included in the delivery. In order to withstand concrete pressure, the units are supported on site by placing backfill material.

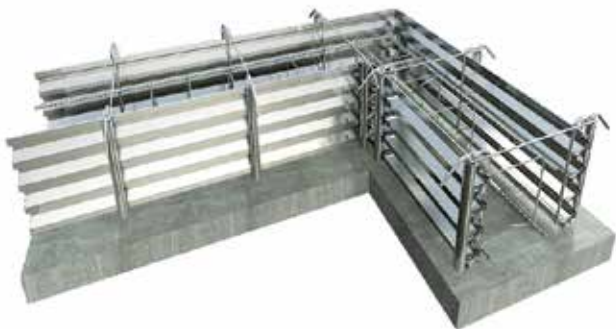

Benefits

- Self-supporting up to 100 cm
- Key profiled metal sheet with / without accessories
- Corner units and other special shapes are produced to the project
- Fast installation
- Highly time-efficient
- Installation without a crane
- Stable structure



Technical data

- Material: galvanized metal sheet, accessories
 - FS type: smooth bars $\varnothing 8$ mm
 - ES type: rebars $\varnothing 8$ mm and $\varnothing 10$ mm / smooth bars $\varnothing 8$ mm depending on dimensions
- Thickness: standard 0,7 mm
- Tubes (KR):
 - $\varnothing 50 \times 2$ mm up to 100 cm
 - $\varnothing 40 \times 1.5$ mm up to 70 cm
 - $\varnothing 30 \times 1.5$ mm up to 50 cm
- Unit height: by order
- Unit length: 225 cm and by order
- Packaging: packed on pallets, shrink wrapped
- Storage: non-stocked/by order



FS type

Length [m]	Height [m]	Width [m]
L= 2.25 & 3.1	H= 0.25 up to 1.25 (greater heights on request)	B=0.2 up to 1.2 (larger widths are available in ES type)



ES type

Length [m]	Height [m]	Width [m]
L= 2.25 & 3.1	H= 0.25 up to 1.25 (greater heights on request)	B>1.20 (smaller widths are available in FS type)



ET type

Length [m]	Height [m]
L= 2.25 & 3.1	H= 0.25 up to 1.6 (greater heights on request)

Installation

Set the 'U'-bars (KU) every $c/c=1.0$ m regarding the position plan of foundation on the previously prepared base. Apply tubes (KR) on bars and set the formwork sheets. Standard overlap between metal sheets is 20 cm, can be adjusted between 15-25 cm in non-standard locations. In case of ET type, use metal screws for tight connection. Stabilize type ES and FS by special clips – in case of FS type there is one internal single 'U'-bar / form tie, in case of ES there are two clips / form ties (KP) inserted between tubes and sheets. Stabilize the width of formwork with 'S'-bar (KC) on the top. ET type does not require accessories but must be backfilled, supported or settled in the ground on site.

Step 1



Step 2



Step 3



Step 4



RECOSTAL[®] Box



RECOSTAL[®] Box is a metal formwork for foundation columns. Trapezoidally profiled and with optional anchors or expanded base, RECOSTAL[®] Box ensure connection of the formwork to poured concrete with superior shear transfer. Most dimension combinations are self-supporting, exemptions depicted in the table.

Benefits

- Easy and low transport costs when flat
- Assembly takes approximately 1 minute
- Trapezoidal profile for superior shear transfer
- Optional base
- Anchors for larger forms



The following variants of RECOSTAL[®] Box are available:

- 1: Assembled
- 2: To be assembled on-site
- 3: To be assembled on-site with self-tapping screws
- 4: With a mesh bottom
- 5: With a metal bottom
- 6: Without a bottom
- 7: With drilled holes
- 8: With cut-out holes



Technical data

- Material: galvanized steel sheet
- Sheet thickness: 0.7, 1.0, 1.5 mm
- Packaging: packed on pallets, shrink wrapped
- A (box width) = 40 – 105 cm
- B (box width) = 40 – 105 cm
- H (box height) = 60 – 200 cm
- Storage: no requirements

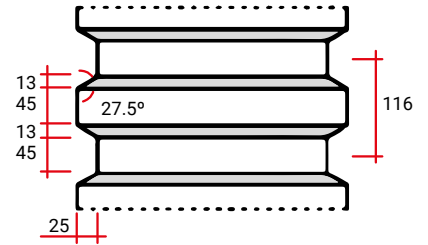
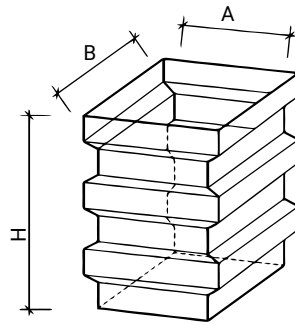
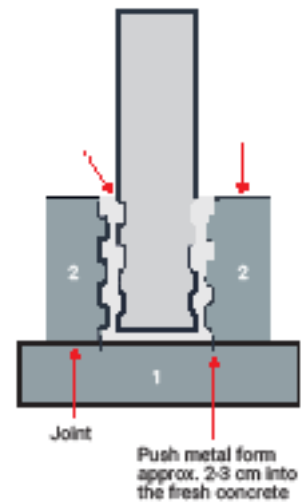
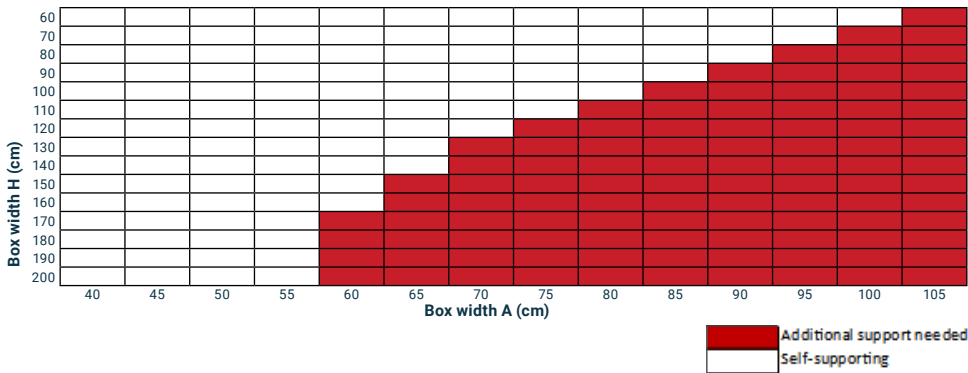
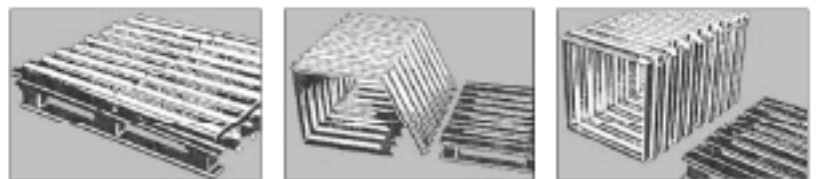

Table 1



Installation

Depending on request RECOSTAL® Box can be delivered to site either flat or preassembled. If flat simply bend the formwork to shape. The assembled RECOSTAL® Box is ready for fixing inside the prepared section.



Required information to place an order

When ordering, the following dimensions must be given:

- 1: Dimensions A x B x H = ... cm
- 2: Metal sheet thickness: 0.7 mm (standard) or 1.0 mm
- 3: With/without bottom

RECOSTAL® Expanded Metal



RECOSTAL® Expanded metal is specifically developed for concrete and reinforced concrete constructions. Bearing capacity and surface structure are perfectly suited to these applications. Strong 21mm high ribs run lengthwise across the sheet. Pressure of fresh concrete is considerably lower compared to solid formwork and only rises to a maximum of 38 kN/m². This value remains constant for concrete heights exceeding 3.0 m.

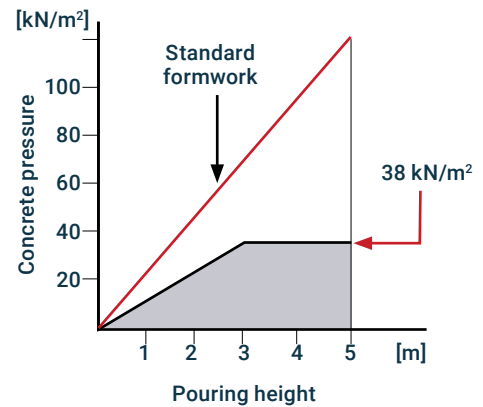

Reinforcement distances

Concrete height [m]	Type 2811 [m]	Type 2911 [m]
0.25	0.70	0.50
0.50	0.60	0.45
1.00	0.50	0.40
1.50	0.40	0.30
2.00	0.35	0.25
2.50	0.25	0.20
3.00	0.20	0.15

The distances for support props are the same as for timber formwork (21mm). This recommendation applies to RECOSTAL® Expanded Metal type 2811. For type 2911 the given numbers are to be reduced by 25%. The values given are recommendations on the basis of the 3 field system.

Benefits

- Strong lengthwise
- Fast Installation
- Shapeable crosswise
- Cut to size

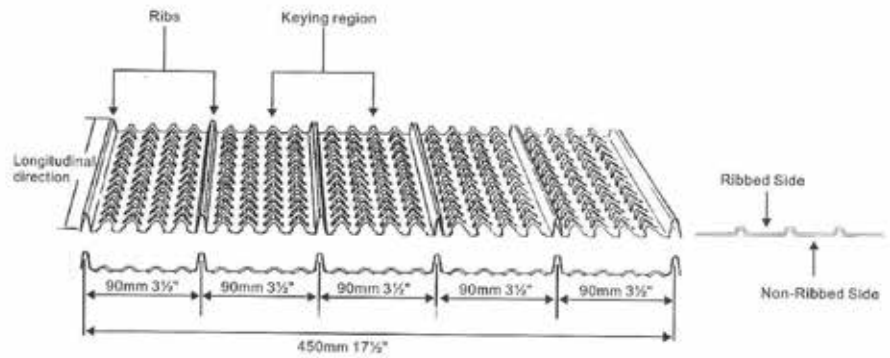

Technical data

- Material: steel
- Unit size: 44.5 x 200 cm
- Types and thickness: 2811/2 – 0.4 mm, 2911/2 – 0.3 mm
- Packaging: packed on pallets, shrink wrapped
- Storage: no limitation

Expanded metal type	Item No.	Thickness [mm]	Size [cm]	Units per pallet
2811/2	19111000	0.4	44.5 x 200	100 sheets = 89 m ²
2911/2	19151000	0.3	44.5 x 200	100 sheets = 89 m ²

Installation

The RECOSTAL® Expanded metal is to be placed between the top and bottom layers of main reinforcement in the concrete element. To prevent leakage and ensure concrete cover it is recommended to use concrete or timber spacers. After placing external supports are to be used at given distances depending on type of expanded metal sheets used. To form corners and regulate length the ribs of the expanded metal sheets are cut and the easily trimmed by hand.



RECASTAL® 1000

RECASTAL® 1000 Formwork is used for making construction joints in reinforcement structures. Necessary for such elements as foundation slab, walls and ceiling

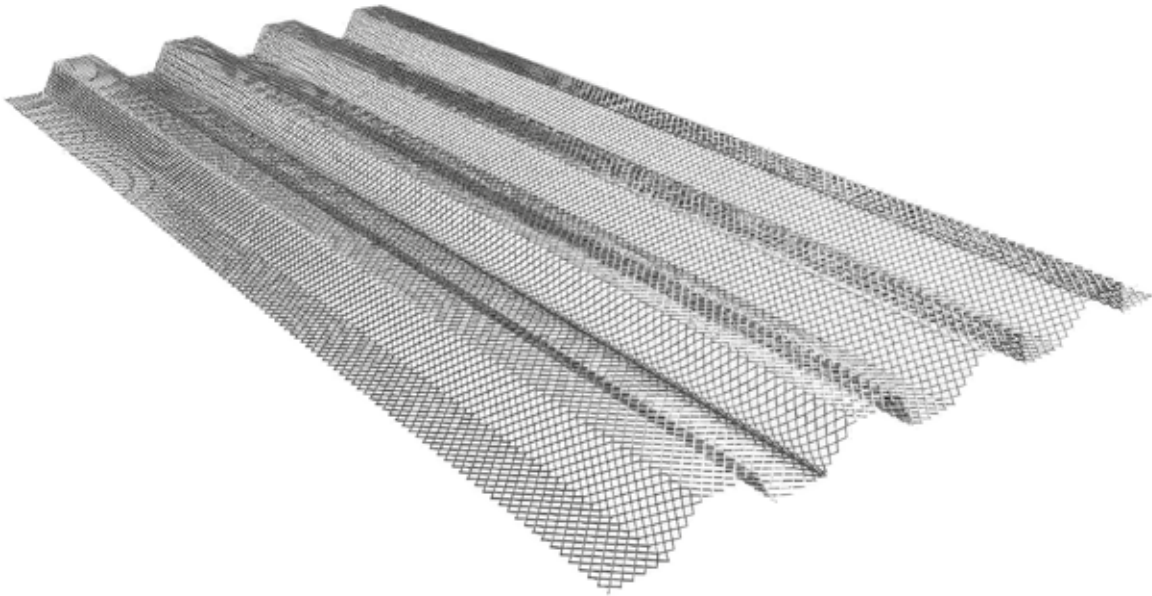

Benefits

- Self-supporting up to 30 cm
- Trapezoidal profile according to Eurocode 2
- Fast installation
- Low transport costs
- Installation without a crane
- Corner units can be manufactured to special order

Technical data

- Material: black steel mesh
- Thickness mesh: standard 1.5 mm (by orders 0.7 mm; 1.0 mm)
- Type of mesh: standard E10 (by orders type E8 for self-compacting concrete)
- Unit height: 100 cm / 120 cm
- Unit length: 225 cm
- Packaging: packed on pallets, shrink wrapped
- Storage: Product should be kept in rooms that are protected from moisture and precipitation. Product should be stored under the roof.

Installation

Position at the location of the designed construction joint, the following should be placed under the lower reinforcement RECOSTAL® Spacecon or concrete spacer. RECOSTAL® 1000 should fix the reinforcement using wire. Overlap between elements is min. 5 cm and should be fix using wire or screw. Over the top reinforcement should be installed RECOSTAL® DFS or wooden scantlings. Once concreting is complete and the concrete mix has set, remove the wooden scantlings.

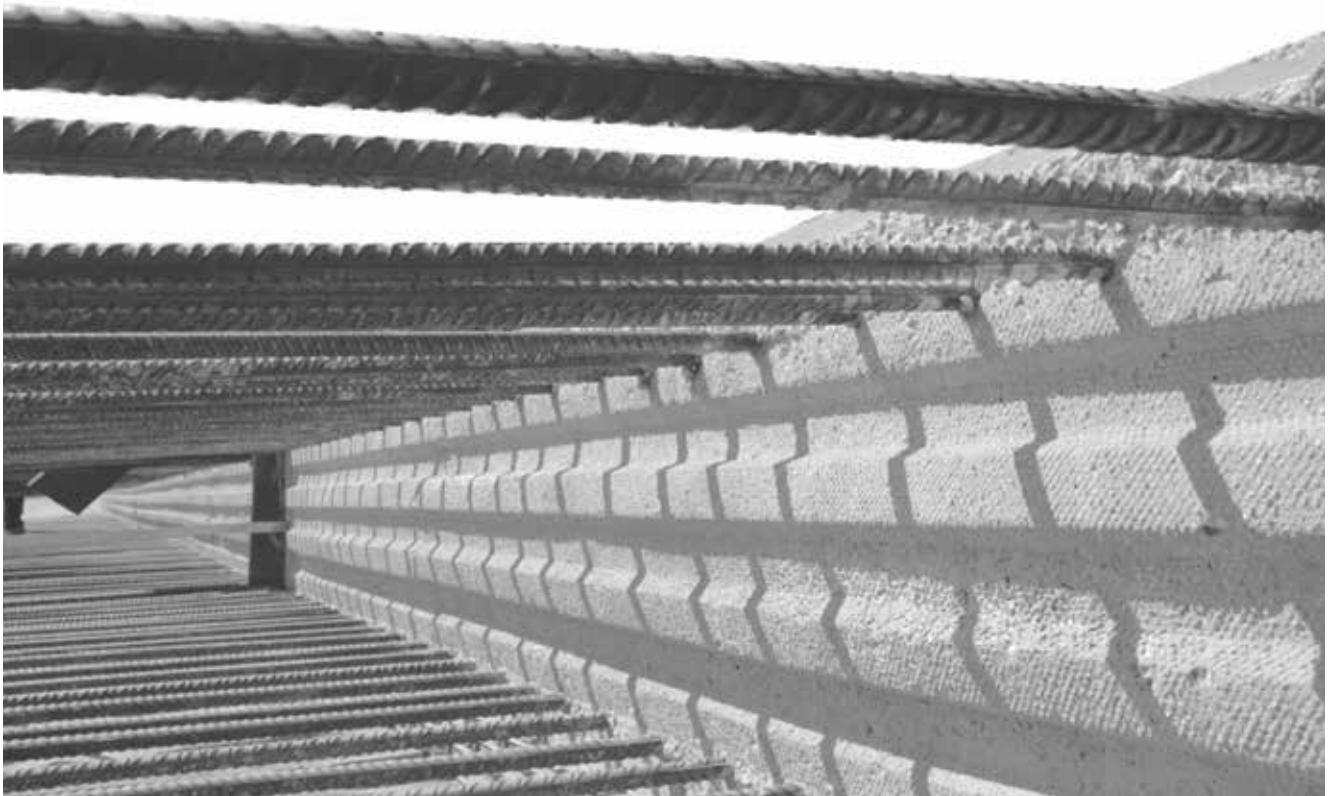

RECOSTAL® 2000/ 2000 Z/ 2000 D



RECOSTAL® 2000/ 2000 Z/ 2000 D are used for making construction joints in reinforcement structures. The load bearing structure is made of rebar mesh.

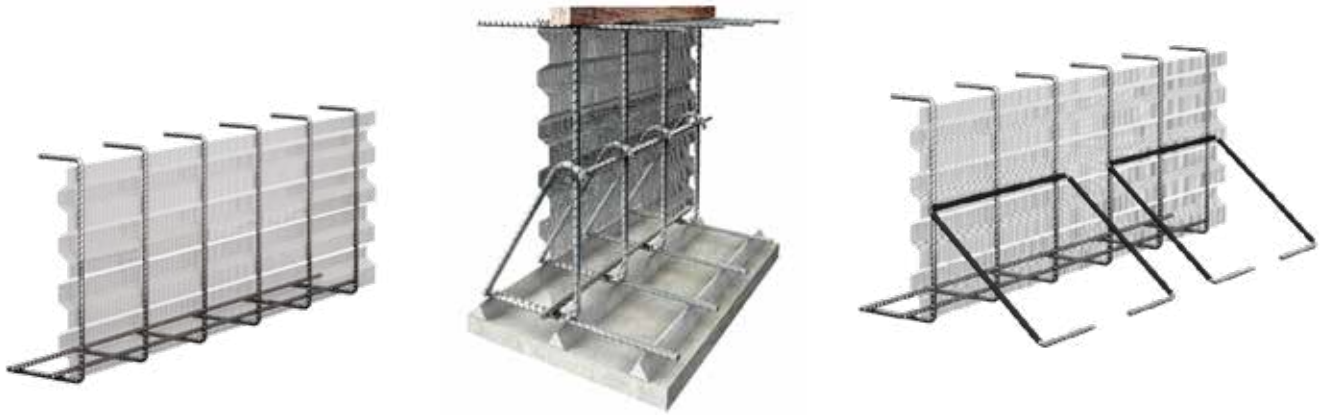

Benefits

- Fully self-supporting in all dimensions and heights to 90 cm
- Trapezoidal profile according to Eurocode 2
- No additional support is necessary
- Fast installation
- Low transport costs
- Installation without a crane
- Corner units can be manufactured to special order

Product variants

- RECOSTAL® 2000 - self-supporting up to 90 cm without additional supporting structure
- RECOSTAL® 2000 Z - for heights up to 2 meters with bracing
- RECOSTAL® 2000 D - for heights up to 2 meters with additional support bars embedded in steel tubes

Technical data

- Material: black steel mesh
- Thickness mesh: standard E10 - 0.7 mm
- Unit length: 225 cm
- Packaging: packed on pallets, shrink wrapped
- Rebars mate: fi. 8; 10; 12 mm
- Horizontal rebars: fi. 20; 25 mm (applies to RECOSTAL® 2000 Z variant only)
- Tie-bars: fi. 12; 16 mm (applies to RECOSTAL® 2000 Z variant only)
- Storage: Product should be kept in rooms that are protected from moisture and precipitation. Product should be stored under the roof

Installation

Position at the location of the designed construction joint, the following should be placed under the lower reinforcement Recostal® Spacecon or concrete spacer. Recostal® 2000/ Recostal® 2000 Z with bracing/ Recostal® 2000 D with additional support bars embedded in steel tubes should fix the reinforcement using welding. Overlap between elements is min. 5 cm. Over the top reinforcement should be installed Recostal® DFS or wooden scantlings. Once concreting is complete and the concrete mix has set, remove the wooden scantlings.



RECOSTAL® 2000 GT/GT-Z



RECOSTAL® 2000 GT/GT-Z Formwork is used for making construction joints in reinforcement structures. The load bearing structure is made of lattice girder. In RECOSTAL® 2000 GT-Z variant, the load bearing structure has in addition horizontal bars and Tie-bars.



Benefits

- Fully self-supporting in all dimensions and heights to 150 cm (RECOSTAL® 2000 GT) or above 150 cm (RECOSTAL® 2000 GT-Z)
- Trapezoidal profile according to Eurocode 2
- No additional support is necessary
- Simplifies application processes, saving time and labor
- Lowers maintenance costs over time by delivering a higher-quality finish
- Corner units can be manufactured to special order
- Reduces wastage by ensuring precision and consistency in concrete formwork
- May reduce the need for secondary materials or corrective measures after concrete curing
- Installation without a crane

Product variants

- RECOSTAL® 2000 GT - without additional support structure
- RECOSTAL® 2000 GT-Z - with additional support structure

Technical data

- Material: black steel mesh
- Thickness mesh: standard 1.5 mm (by orders: 0.7 mm; 1.0 mm)
- Unit height: on order
- Unit length: 225 cm
- Packaging: packed on pallets, shrink wrapped
- Load bearing: lattice girder
- S (Space) = 4 cm
- Storage: Product should be kept in rooms that are protected from moisture and precipitation. Product should be stored under the roof.
- Available on demand

Installation

Position at the location of the designed construction joint, the following should be placed under the lower reinforcement RECOSTAL® Spacecon or concrete spacer. RECOSTAL® 2000 GT/ GT-Z should fix the reinforcement using welding and in RECOSTAL® 2000 GT-Z version, additional lattice girder and Tie-bars should fix the reinforcement using welding. Overlap between elements is min. 5 cm. Over the top reinforcement should be installed RECOSTAL® DFS or wooden scantlings. Once concreting is complete and the concrete mix has set, remove the wooden scantlings.

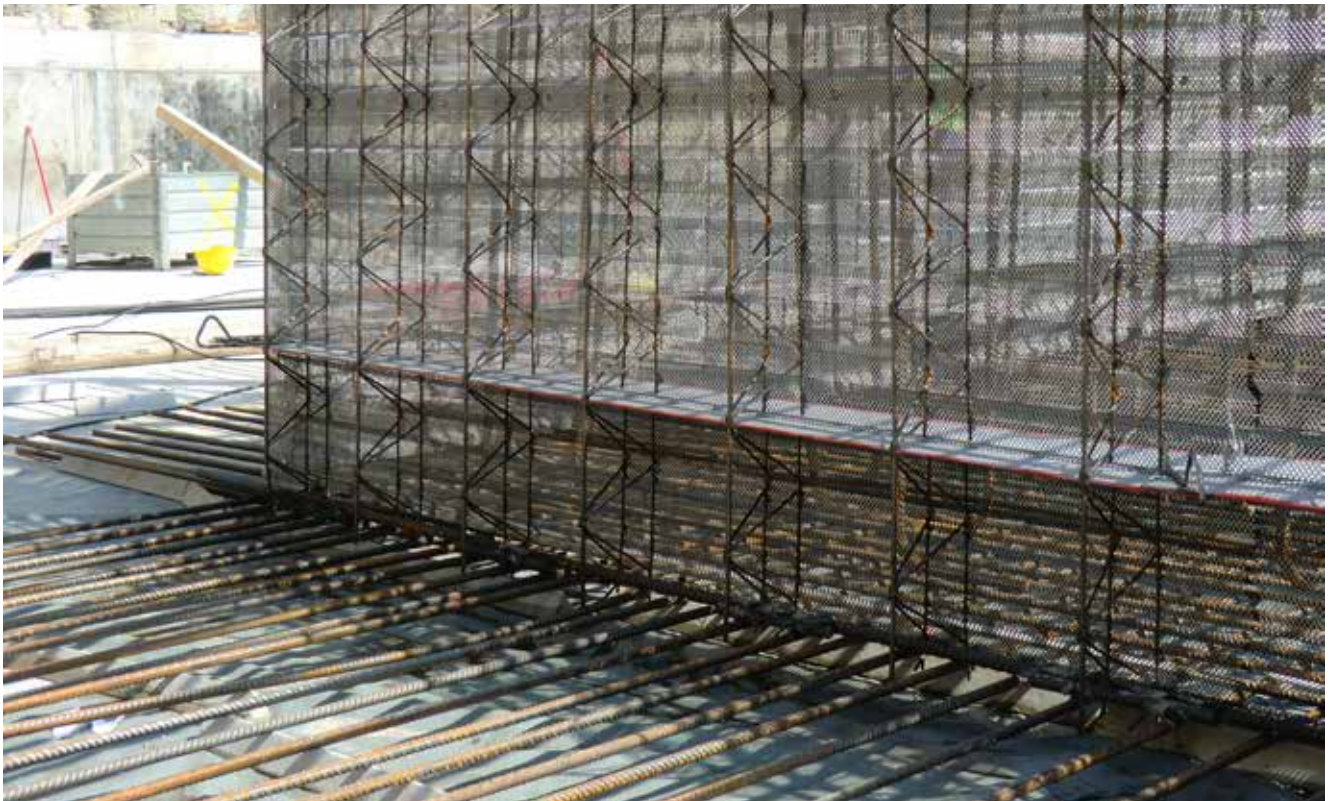



RECOSTAL® Edge Forms

The use of RECOSTAL® Edge Forms improves the seal of joints and enhances the interaction between connected elements. It allows for the installation of a seal in construction joints with uniform concrete embedding. It is mainly used at the connection between the foundation slab and walls, as well as in recesses, separators, and elevator pits.

Benefits

- Easy and quick installation
- Improved joint sealing by extending the water path and ensuring uniform concrete embedding on both sides of sealing sheets or PVC tapes
- Simple connection of consecutive elements
- Compatibility with various sealing components, such as: metal waterstop contaflexactiv, Bituflex, contecSEAL, conSTIC, PVC tapes
- Facilitates achieving a greater concrete cover for the upper reinforcement bars when the design cover is 2–3 cm.



Product variants

System A1

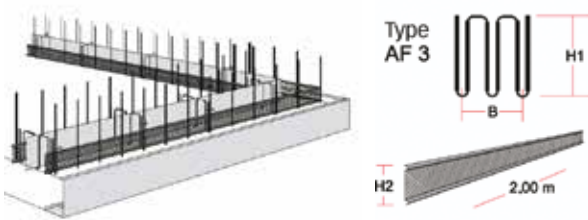

System A2

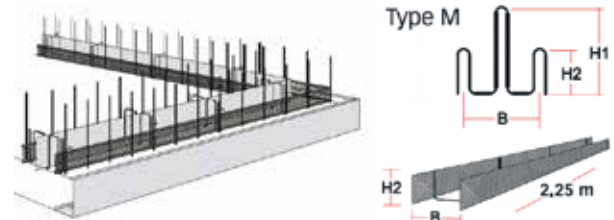

System A3

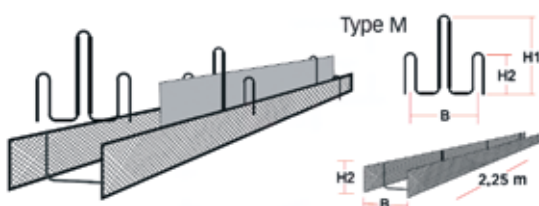

System A4

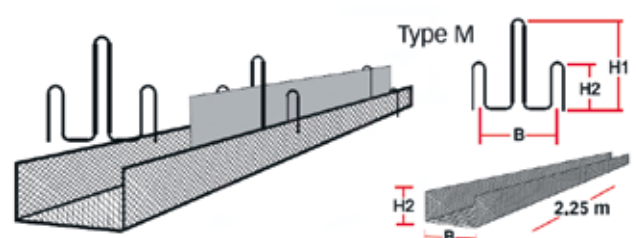



RECOSTAL® 1000 F

RECOSTAL® 1000 F Formwork with metal waterstop is used for making construction joints in reinforcement structures of foundation slabs, reinforced concrete walls and in ceilings. Shuttered units with metal waterstop ensures the tightness of the construction joint.

Construction Joints
with Sealing

RECOSTAL® 1000 F

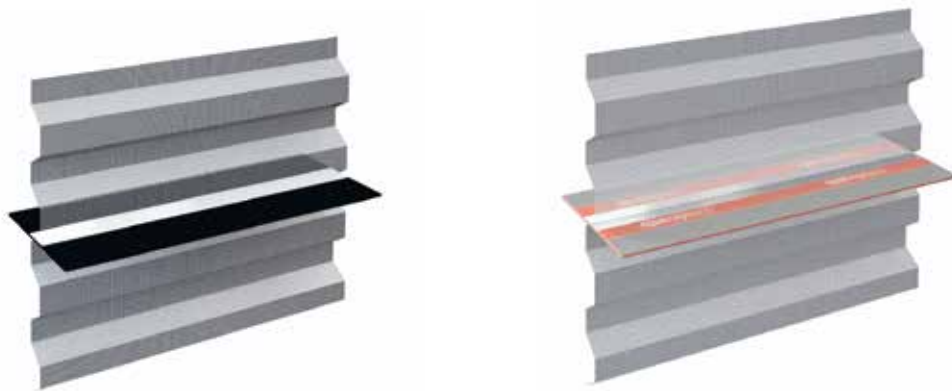

Benefits

- Self-supporting up to 30 cm
- Metal waterstop with activ bentonite or bituminous coating
- Working interval tightness up to 0.5 MPa with constant pressure and also with variable pressure
- Active bentonite has been tested for continuous tightness of the working break even after a drying period
- Available metal waterstop without any coating
- Trapezoidal profile according to Eurocode 2
- Fast installation
- Low transport costs
- Installation without a crane
- Corner units can be manufactured to special order

Product variants

- RECOSTAL® 1000 F activ – metal waterstop with active bentonite
- RECOSTAL® 1000 F bitum – metal waterstop with bitum

Technical data

- Material: black steel expanded metal mesh
- Thickness mesh: standard 1.5 mm (on order: 0.7 mm; 1.0 mm)
- Metal waterstop: galvanised metal sheet standard 1.2 mm (on order: 1.5 mm; 2.0 mm)
- Type of mesh: standard E10 (on order type E8 for self-compacting concrete)
- Unit height: on order
- Unit length: 225 cm
- Packaging: packed on pallets, shrink wrapped
- Storage: Product should be kept in rooms that are protected from moisture and precipitation.
Do not store in the sun. Product should be stored under the roof.

Installation

Position at the location of the designed construction joint, the following should be placed under the lower reinforcement RECOSTAL® Spacecon or concrete spacer. RECOSTAL® 1000 F should fix the reinforcement using wire. Up to a height of 30 cm does not require support, but above this height we recommend a support structure. The overlap of the metal waterstop with coating is 10 cm, on each overlap should be mounted clamps K 18/3. The overlap between the meshes is according to the selected standard which should be secured with an additional sheet of mesh screwed with screws. Above the upper reinforcement, we install RECOSTAL® DFS or set a wooden scantling. After concreting is completed and the concrete mixture has set, we remove the wooden scantling.



RECOSTAL® 2000 F

RECOSTAL® 2000 F is a lost formwork system combined with a load-bearing structure and a sealing sheet, designed for creating construction joints in reinforced concrete structures such as foundation slabs and floors. The lost formwork incorporates a sealing sheet that ensures the tightness of the construction joint.

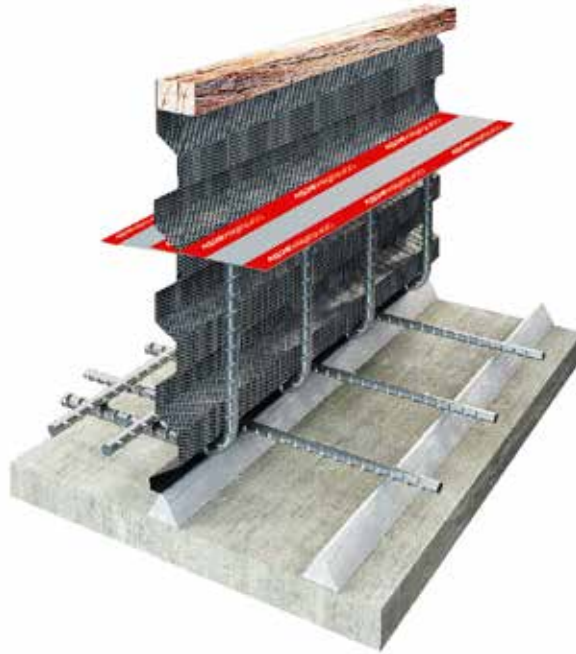

Benefits

- Self-supporting structure up to 90 cm
- The sealing sheet ensures the tightness of the construction joint up to 50 m H₂O under continuous or variable pressure
- Active bentonite has been tested for continuous joint sealing, even after drying periods
- Trapezoidal profile compliant with EC 2 standards
- Fast installation process
- Low transportation cost
- Installation possible without the use of a crane

Product variants

- RECOSTAL® 2000 F activ - Sealing sheet with an active bentonite layer
- RECOSTAL® 2000 F bitum - Sealing sheet with a bitumen layer

Technical data

- Material: expanded metal mesh made from black steel sheet
- Mesh thickness: standard 0.7 mm
- Mesh type: standard E10 (E8 type available for self-compacting concrete upon request)
- Metal waterstop: standard: 1.2 mm galvanized steel (1.5 mm or 2.0 mm available upon request)
- Element height: customizable upon request
- Element length: 225 cm
- Packaging: stretch-wrapped pallet
- Supporting structure: reinforcing bars with diameters of 8 mm, 10 mm, or 12 mm
- Storage: Store in areas protected from moisture and precipitation.
Avoid storing in direct sunlight; product should be kept under shelter.

Installation

At the location of the designed construction joint, place RECOSTAL® Spacecon or a concrete spacer beneath the lower reinforcement to ensure the proper bottom cover for the reinforcement bars. RECOSTAL® 2000 F should be attached to the reinforcement bars using binding wire or welding.

The overlap of the sealing sheets should be 10 cm, and a K 18/3 clamp must be installed on each overlap. The overlap between the mesh sheets should be 1 cm, secured with an additional mesh sheet fastened with screws.

Above the upper reinforcement, install RECOSTAL® DFS or position a wooden batten. After concreting and the concrete mix has set, remove the wooden batten.



RECOSTAL® 2000 GTF/GTF-Z

RECOSTAL® 2000 GTF/ GTF-Z Formwork with metal waterstop and lattice girder is used for making construction joints in reinforcement structures of foundation slabs and ceilings. Shutedred units with metal waterstop ensures the tightness of the construction joint. To ensure greater rigidity, the load-bearing structure of RECOSTAL® 2000 GTF-Z is made of trusses, longitudinal bars, and braces.

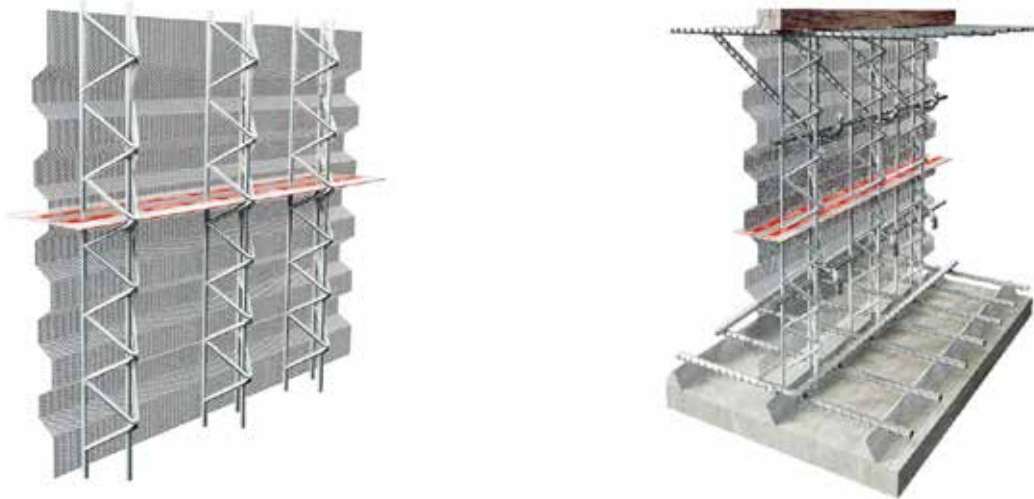

Benefits

- Self-supporting up to 150 cm (RECOSTAL® 2000 GTF) and more than 150 cm (RECOSTAL® 2000 GTF-Z)
- Metal waterstop with activ bentonite or bituminous coating
- Working interval tightness up to 5 bars with constant pressure and also with variable pressure
- Active bentonite has been tested for continuous tightness of the working break even after a drying period
- Available metal waterstop without any coating
- Trapezoidal profile according to Eurocode 2
- No additional support is necessary
- Fast installation
- Low transport costs
- Installation without a crane
- Corner units can be manufactured to special order

Product variants

- RECOSTAL® 2000 GTF activ – metal waterstop with active bentonite
- RECOSTAL® 2000 GTF-Z bitum – metal waterstop with bitum

Technical data

- Material: black steel expanded metal mesh
- Thickness mesh: standard 1.5 mm (on order 0.7 mm; 1.0 mm)
- Type of mesh: standard E10 (on order type E8 for self-compacting concrete)
- Metal waterstop: galvanised metal sheet standard 1.2 mm (on order 1.5 mm; 2.0 mm)
- Unit height: on order
- Unit length: 225 cm
- Packaging: packed on pallets, shrink wrapped
- Load bearing: lattice girder
- S (Space) = 4 cm
- Storage: Product should be kept in rooms that are protected from moisture and precipitation.
Do not store in the sun. Product should be stored under the roof.

Installation

Position at the location of the designed construction joint, the following should be placed under the lower reinforcement RECOSTAL® Spacecon or concrete spacer. RECOSTAL® 2000 GTF should fix the reinforcement using welding. Up to a height of 30 cm does not require support, but above this height we recommend a support structure. The overlap of the metal waterstop with coating is 10 cm, on each overlap should be mounted clamps K 18/3. The overlap between the meshes is according to the selected standard which should be secured with an additional sheet of mesh screwed with screws. Above the upper reinforcement, we install RECOSTAL® DFS or set a wooden scantling. After concreting is completed and the concrete mixture has set, we remove the wooden scantling.





RECOSTAL® 3000

Crack Joints

RECOSTAL® 3000

RECOSTAL® 3000 Formwork is used for making crack joint in reinforcement structures. Necessary for such elements as foundation slab, walls and ceiling.



Benefits

- Provides a controlled crack in a reinforcement structure
- Trapezoidal profile according to Eurocode 2
- Fast installation
- Low transport costs
- Installation without a crane
- Corner units can be manufactured to special order

Technical data

- Material: galvanized metal sheet
- Thickness mesh: standard 0.7 mm
- Unit length: 225 cm
- Packaging: packed on pallets, shrink wrapped
- Storage: Product should be kept in rooms that are protected from moisture and precipitation.
Product should be stored under the roof.

Installation

Position at the location of the designed crack joint, the following should be placed under the lower reinforcement concrete spacer. RECOSTAL® 3000 should fix the reinforcement using wire. Overlap between elements is min. 5 cm. With the use a profile for crack joint RECOSTAL® 3000, we can concrete large areas of reinforced concrete slabs at the same time.



RECOSTAL® 3000 F

Crack Joints

RECOSTAL® 3000 F

RECOSTAL® 3000 F is a lost formwork system made of solid sheet metal combined with a metal waterstop sheet, used to create controlled cracks in reinforced concrete structures such as foundation slabs, reinforced concrete walls, and floors. The lost formwork includes a metal waterstop sheet that ensures the tightness of the resulting crack.

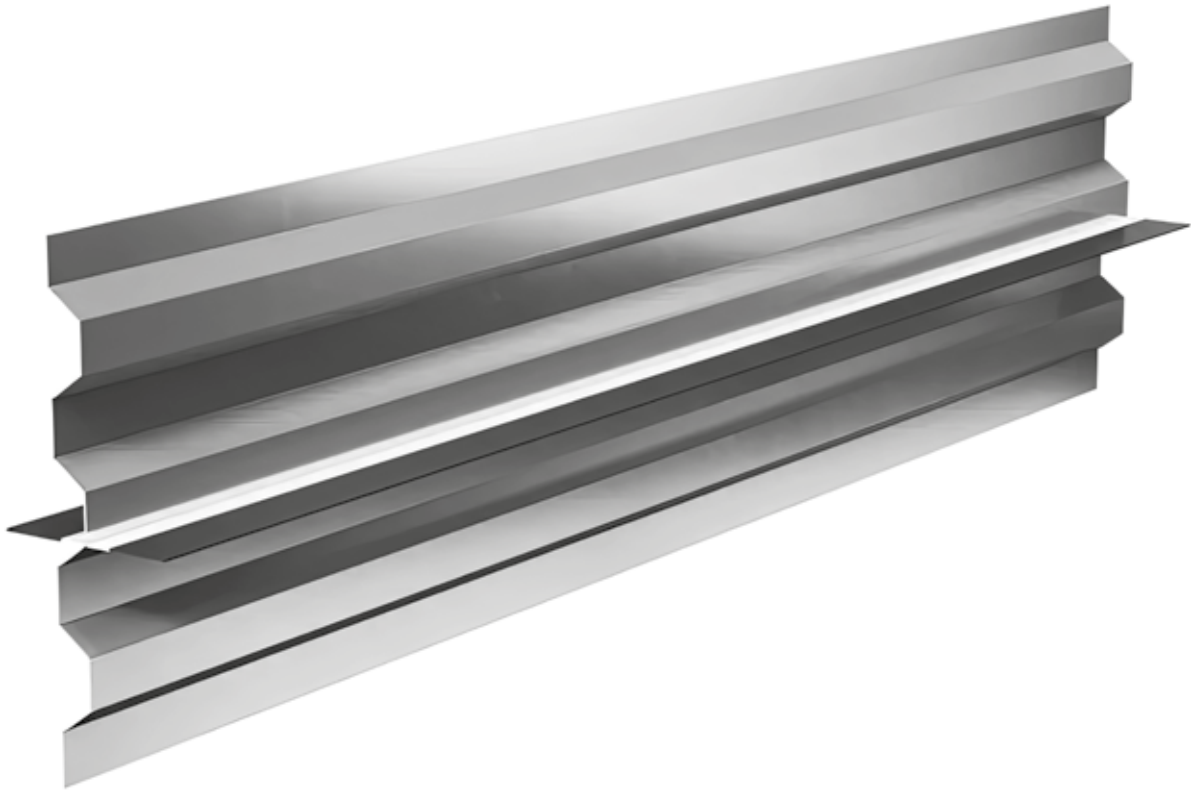

Benefits

- Ensures the formation of a controlled crack in reinforced concrete structures
- Sealing sheet with an active bentonite or bitumen layer
- Tightness of the construction joint up to 50 mH₂O under continuous or variable pressure
- Active bentonite has been tested for continuous joint tightness, even after drying periods
- Trapezoidal profile compliant with EC 2 standards
- Quick and easy installation
- Low transportation cost
- Installation without the use of a crane.

Technical data

- Material: galvanized sheet metal
- Sheet thickness: 0.7 mm
- Sealing sheet: standard 1.2 mm galvanized steel (options: 1.5 mm or 2.0 mm upon request)
- Element height: customizable upon request
- Element length: 225 cm
- Packaging: stretch-wrapped pallet
- Storage: Store in areas protected from moisture and precipitation.
Avoid storing in direct sunlight; the product should be stored under shelter.

Installation

1. Positioning

At the location of the designed crack in the reinforced concrete structure, attach RECOSTAL® 3000 F to the reinforcement bars using binding wire.

2. Overlaps

The overlap between elements must comply with the chosen standard and be secured with a mesh fastened using screws.

The overlap of sealing sheets should be 10 cm, secured with a K 18/3 clamp.

3. Concreting

Pour the concrete mix evenly on both sides of the formwork to ensure proper embedding.



RECOSTAL[®] DFI

Expansion Joints

RECOSTAL[®] DFI

RECOSTAL[®] DFI is a permanent formwork made of metal sheet and rebars, allows shoring of expansion joint and internal PVC tape installation at the same time. Using this product, concreting on both sides of the structure is possible.



Benefits

- Self-supporting up to 70 cm – standard element
- Possibility of modifying the element to increase self-support
- Flat metal sheet with welded ribs and bars, quantity depending on height
- Height manufactured by order
- Corner units and other special shapes are produced to the project
- Fast installation
- Installation without a crane
- The ability to create the entire system for foundation slab, walls and ceiling



Technical data

- Material: galvanized metal sheet, smooth bars $\varnothing 8$ mm
- Thickness: standard 0.7 mm and 1.2 mm for lower height
- Filling material: EPS, XPS, Rockwool (other regarding project)
- Unit height: by order
- Unit length: 225 cm and 220 cm
- Packaging: packed on pallets, shrink wrapped
- Storage: non-stocked/by order

Installation

The bottom part of RECOSTAL® DFI should be installed to the bedding concrete using nails. PVC tapes should be unrolled and located in the middle of the product regarding requirements of Producer. Then, the upper and bottom part should be joined with tie wire/welding very tight. Use metal plates to install next element by sheet-metal screws. After concreting, remove top strip, then fill the gap by sealing mass onsite.

Associated system products

- PVC TAPES
- DOWELS $\varnothing 16, \varnothing 20, \varnothing 25$ mm
- PVC SLEEVES FOR DOWELS $\varnothing 16, \varnothing 20, \varnothing 25$ mm





RECOSTAL[®] DFA

Expansion Joints

RECOSTAL[®] DFA

RECOSTAL[®] DFA is a permanent formwork made of metal sheet and rebars, allows shoring of expansion joint and external PVC tape/waterstop installation at the same time. Using this product, concreting on both sides of the structure is possible.



Benefits

- Self-supporting
- Possibility of modifying high element to increase self-support
- Flat metal sheet with welded bars, quantity depending on height
- Height manufactured by order
- Corner units and other special shapes are produced to the project
- Fast installation
- Installation without a crane
- The ability to create the entire system for foundation slab, walls

Technical data

- Material: galvanized metal sheet, smooth bars Ø8 mm
- Thickness: standard 0.7 mm
- Filling material: EPS, XPS, Rockwool (other regarding project)
- Unit height: by order
- Unit length: 225 cm and 220 cm
- Packaging: packed on pallets, shrink wrapped
- Storage: non-stocked/by order

Installation

PVC tape/waterstop should be unrolled and located in the place of planned expansion joint, regarding requirements of the Producer. RECOSTAL® DFA should be installed above the tape/waterstop to the bedding concrete using nails. Use metal plates to install the next element by sheet-metal screws. After concreting, remove the top strip, then fill the gap by sealing mass onsite.

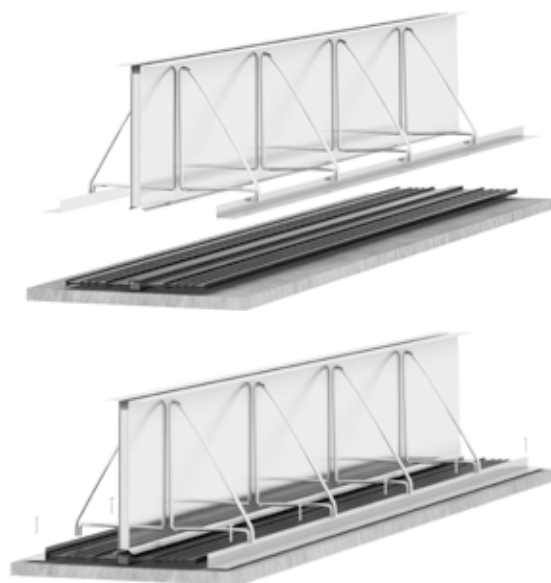

Associated system products

- PVC TAPES
- DOWELS Ø16, Ø20, Ø25 mm
- PVC SLEEVES FOR DOWELS Ø16, Ø20, Ø25 mm



RECOSTAL[®] DFI-DFA

Expansion Joints

RECOSTAL[®] DFI-DFA

RECOSTAL[®] DFI-DFA is a permanent formwork made of galvanized metal sheet, bars and additional supports made with lattice girder or bars, allows shoring of expansion joint and internal + external PVC tapes/waterstops installation at the same time. Using this product, concreting on both sides of the structure is possible.



Benefits

- Self-supporting
- Possibility of modifying the element
- Flat metal sheet with welded ribs and bars, quantity and type depending on height
- Height manufactured by order
- Corner units and other special shapes are produced to the project
- Fast installation
- Installation without a crane
- The ability to create the entire system for foundation slab, walls and ceiling

Technical data

- Material: galvanized metal sheet, smooth bars Ø8 mm
- Thickness: standard 0.7 mm; 1.2 mm
- Filling material: EPS, XPS, Rockwool (other regarding project)
- Unit height: by order
- Unit length: 225 cm and 220 cm
- Packaging: packed on pallets, shrink wrapped
- Storage: non-stocked/by order

Installation



The external PVC tape/waterstop should be unrolled and located in the place of planned expansion joint, regarding requirements of Producer.



The bottom part of RECOSTAL® DFI-DFA should be installed above the tape to the bedding concrete using nails.



PVC tapes should be unrolled and located in the middle of the product regarding requirements of Producer.



Then, the upper and bottom part should be joined with tie wire/welding very tight. Use metal plates to install next element by sheet-metal screws.



After concreting, remove top strip, then fill the gap by sealing mass onsite.

Associated system products

- PVC TAPES
- DOWELS Ø16, Ø20, Ø25 mm
- PVC SLEEVES FOR DOWELS Ø16, Ø20, Ø25 mm



RECOSTAL® Keyboard XL/XL-D

Crack Inducer

RECOSTAL® XL/XL-D

RECOSTAL® Keyboard XL units are designed for the installation of isolation joints in industrial floor slabs and deck slabs with controlled cracks along the joint. The trapezoidal profile induces a key-profiled control joint. To withstand stronger shear forces, the RECOSTAL® Keyboard XL unit can also be equipped with dowel bars. The available RECOSTAL® Keyboard XL-D variant is used to create dilatations.



Benefits

- Trapezoidal profile
- Fast Installation
- Special types and sizes on request
- Adjustable height with KBS formbrace
- Optional dowel bars, sleeves and openings
- Joint expansion less than 3 mm
- For XL-D variant, standard dilatation thickness 1 cm

Technical data

- Material: galvanized steel sheet
- Unit length: 300 cm
- Dilatation: styrofoam 1 cm (different thickness on request)
- Packaging: packed on pallets, shrink wrapped
- Unit height = 145 - 265 mm
- Storage: no limitation

Keyboard Type	Formbrace Type	Unit Height [mm]	Slab Height [mm]
XL 180	KBS 180	145	180
XL 200	KBS 200	165	200
XL 250	KBS 250	215	250
XL 300	KBS 300	265	300

Installation

The keyboard KBS formbraces are positioned at distances of approx. 1.00 m (note sticker pointing out direction) and rigidly fixed with pegs and/or mortar. Then the keyboard units are placed into the formbraces, adjusted in height and lap joints are fixed with the plastic screws included in the delivery. After that the plastic cap strips are attached to the unit. In low temperatures we recommend softening the plastic cap strip in warm water.

Associated system products

- PVC cap strip type 75E
- PVC cap strip type 120E
- PVC cap strip type 95P
- Dowel sleeve, PVC, for dowel bars \varnothing 20 mm
- Dowel bar \varnothing 20 mm
- KBS formbrace



RECOSTAL[®] Keyboard XLV/XLW-D

Crack Inducer

RECOSTAL[®] XLV/XLW-D

RECOSTAL[®] Keyboard XLV/XLW units are designed for the installation of isolation joints in industrial floor slabs and deck slabs with controlled cracks along the joint. The trapezoidal profile induces a key-profiled control joint. The top of the units consists of edge protection profiles which protect the concrete edges from spalling. There is a choice between type XLV and type XLW, depending on the respective requirement for edge protection. To withstand stronger shear forces, the RECOSTAL[®] Keyboard XLS unit can also be equipped with dowel bars. The available RECOSTAL[®] Keyboard XLV-D/XLW-D variants are used to create dilatations.



Benefits

- Trapezoidal profile
- Steel edge protection
- Fast Installation
- Special types and sizes on request
- Adjustable height with KBS formbrace
- Optional dowel bars, sleeves and openings
- Joint expansion up to 12 mm
- For XLV-D/XLW-D variants, standard dilatation thickness 1 cm

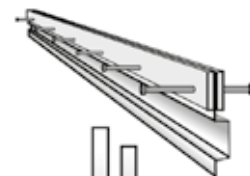

Keyboard XLV

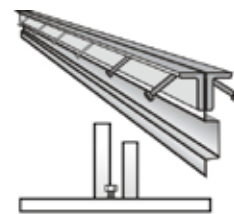

Keyboard XLW

Technical data

- Material: galvanized steel sheet
- Edge protection material: black steel with welded bolts or stainless steel
- Unit length: XLV - 295 cm; VLW - 300 cm
- Dilatation: styrofoam 1 cm (different thickness on request)
- Packaging: packed on pallets, shrink wrapped
- Unit height = 145 - 265 mm
- Storage: no limitation

Keyboard Type	Formbrace Type	Unit Height [mm]	Slab Height [mm]
XLV/XLW 180	KBS 180	145	180
XLV/XLW 200	KBS 200	165	200
XLV/XLW 250	KBS 250	215	250
XLV/XLW 300	KBS 300	265	300

Installation

The keyboard KBS formbraces are positioned at distances of approx. 1.00 m (note sticker pointing out direction) and rigidly fixed with pegs and/or mortar. Then the keyboard units are placed into the formbraces, adjusted in height and lap joints are fixed with the plastic screws included in the delivery. After that the plastic cap strips are attached to the unit.

Associated system products

- Dowel sleeve, PVC, for dowel bars \varnothing 20 mm
- Dowel bar \varnothing 20 mm
- KBS formbrace



RECOSTAL® KEYBOARD XLS/ XLS-D

Crack Inducer

RECOSTAL® XLS/ XLS-D

RECOSTAL® Keyboard XLS units are designed for the installation of isolation joints in industrial floor slabs and deck slabs with controlled cracks along the joint. The trapezoidal profile induces a key-profiled control joint. A sinusoidal edge protection profile with an amplitude of 75 mm forms the top of the unit to prevent spalling of concrete edges and to ensure vibration and shock-free passage of mobile materials handling trucks with different types of wheels over the construction-related joints in large-area industrial floor slabs. To withstand stronger shear forces, the RECOSTAL® Keyboard XLS unit can also be equipped with dowel bars. The available RECOSTAL® Keyboard XLS-D variant is used to create dilatations.



Benefits

- Trapezoidal profile
- Sinusoidal edge protection
- Fast Installation
- Special types and sizes on request
- Adjustable height with KBS formbrace
- Optional dowel bars, sleeves and openings
- Joint expansion up to 12 mm
- For XLS-D variant, standard dilatation thickness 1 cm

Technical data

- Material: galvanized steel sheet
- Edge protection material: black steel with welded bolts
- Unit length: 295 cm
- Dilatation: styrofoam 1 cm (different thickness on request)
- Packaging: packed on pallets, shrink wrapped
- Unit height = 145 - 265 mm
- Storage: no limitation

Keyboard Type	Formbrace Type	Unit Height [mm]	Slab Height [mm]
XLS 180	KBS 180	145	180
XLS 200	KBS 200	165	200
XLS 250	KBS 250	215	250
XLS 300	KBS 300	265	300

Installation

The RECOSTAL® Keyboard KBS formbraces are positioned at distances of approx. 1.00 m (note sticker pointing out direction) and rigidly fixed with pegs and/or mortar. Then the keyboard units are placed into the formbraces, adjusted in height and lap joints are fixed with the plastic screws included in the delivery. After that the plastic cap strips are attached to the unit.

Associated system products

- Dowel sleeve, PVC, for dowel bars \varnothing 20 mm
- Dowel bar \varnothing 20 mm
- KBS formbrace



RECASTAL[®] Lost Formwork Technologies



**Foundations and
combined footings**



Openings



Expansion joints



Construction joints



**Crack inducer
for industrial floors**



Lintels and tie beams

Get in touch.

For local contact details,
please visit our website.



concrete.dywidag.com/contact

© Copyright 2024 DYWIDAG. All rights reserved.
Specifications subject to change without notice.



concrete.dywidag.com